



LES CERISIES  
CHALET & SPA

Chalet with outdoor jacuzzi, steam rooms,  
panoramic sauna, massage parlour & private cinema.  
Breathtaking Mont Blanc views.



“Welcome to  
your home”

*Dear Guests,*

*First and foremost, it's a real pleasure to welcome you. Thank you for choosing this little corner of paradise to spend your holidays. I hope that you will be as enchanted by Cordon, the “balcony of Mont Blanc”, as we were on our first visit.*

*My husband and I lived in the Paris suburbs for 20 years, opposite a drab 8-storey building, but we couldn't resist the peace and quiet and the spectacular views of the mountains. Now we live between Cordon and Combloux to “rent weeks of happiness”.*

*As lovers of beauty, we strive every off-season to make the inside as soothing as the outside. Always on the lookout for unique pieces, we're constantly on the lookout for that special piece of furniture with a patina, or that special material, or the finish that will enhance the design icon with which it will be associated.*

*Far from standard rentals, we wanted to give this chalet a soul. We sincerely hope that you will feel at home straight away... just like in your family home.*



## Here's all the information you need to make your holiday even more enjoyable

When you arrive, if you wish, reverse along the ramp to make it easier to unload your luggage. You can then park in the **2 covered car parks**. If you have a third vehicle, park it perpendicular to the first two. Parking spaces are scarce in Cordon, so avoid parking on the shuttle bus in front of the chalet or in the spaces of the neighbouring gîte. There is a **large free car park in the centre of the village**, where you can easily park extra cars.

Lighting for the garage, sign and lanterns is automatic. We recommend that you leave the **outside lights** on when you go out after dark. The switches (with the three small indicator lights) are located next to the bay window, to the right of the workbench and next to the front door. Don't forget to turn them off when you get home.

The **ski room** is at the back of the garage on the left, and you have been given the key to get there. You can use the dryers to find your ski boots dry and warm the next day, as well as your gloves, hats and helmets. The heating and blower switches are located on the side of each unit.

The **bike room** is at the back of the garage on the right, where you can safely leave your mountain bikes, as well as charging and servicing them if necessary.  
*(This facility will be operational in spring 2024).*

**Everything in the chalet is at your disposal during your stay.** We leave a small **grocery**, **Nespresso** capsules and the bottles in the bar at your disposal. If you'd like to take Savoyard cheeses and charcuterie home with you, there's a **vacuum-packing drawer** in the kitchen (the bags are above the wine cellar). To open the kitchen wine cellar, push the top left-hand corner. If you'd like to try your hand at some tasty low-temperature cooking, there's a cooking drawer for you. Don't look for the washing-up liquid, it's hidden in a pump dispenser to the left of the sink.

What a pleasure it is to cook on a granite worktop that's not afraid of scratches or heat! But it will be **eaten away by bleach, vinegar and alcohol**. Avoid these products or rinse the stone quickly with soapy water.

To the left of the kitchen mixer tap, you'll find two touch-sensitive buttons. The top one (blue) will dispense **filtered, chilled water**, while the bottom one (green) will dispense **sparkling water**, also filtered and chilled. Press the button again to stop dispensing water. Additional CO2 cartridges are located in the plinths under the sink. You'll recognise the full bottles by their sealed caps.

If you love your **Thermomix**, there's no need to bring your own - you'll find one on site. If you prefer traditional cooking, you'll find plenty of books hidden away on the shepherd's table. Pastry, plancha, barbecue or vegetarian, you'll find all the inspiration you need to treat yourself. Surprise yourself by cooking vegan like a chef. We've got everything you need to prepare these delicious recipes: **juice extractor, super blender, dehydrator...**



From spring to autumn, lemon balm, mint, sage, chives, thyme, oregano, marjoram, perpetual onion, rocket, sorrel... grow in abundance in the **aromatic kitchen garden**. Help yourself!

You'll find a **second, larger wine cellar** on the garden floor. We offer an **honesty bar service**. The principle is simple: the prices are indicated on the menu, just help yourself, taste and enjoy, and tell us what you've drunk at the end of your stay.

All the **operating instructions** for the appliances are stored in the two drawers located under the hob at baseboard level.

There are two **waste separation bins** under the sink and a bottle holder at the entrance to the kitchen. You should dispose of your rubbish in the "moloks" containers 200 m down the road towards the village. You can also do your bit for the environment by putting your garden waste on the **compost** heap opposite the sauna. This will help to improve the soil in the vegetable garden.

You'll find **cleaning products and a Hoover** in the upstairs toilet cupboard and in the hall column.

A washing machine and tumble dryer are available in the cellar. The washing machine is equipped with TwinDos technology, so there's **no need to add detergent**. All you have to do is select white or colour, and the detergent will be automatically dosed and injected. If you prefer to dry your clothes naturally, two drying racks fold out to accommodate your wet clothes. They are located on the outside door to the right of the cinema entrance.

We have installed a **drying cabinet** between the two upstairs suites. You'll find it easy to iron your dresses fresh from your luggage, deodorise and dry your technical clothes after a day

of sport, iron and mark the creases in trousers, disinfect a cuddly toy... We're sure you'll love it.

There's also a **steam iron** in the cupboard in the "Aravis" suite, so you can iron your clothes like a pro if you like.

Here's the essential **WiFi**; network: [Chalet](#), Code: [les Cerises](#).

The telephone gives you access to national landline numbers. You can also call us on +33 4 50 98 32 12.

You'll find **board games** in the box under the **PS4** screen in the "Mont-Blanc" suite. A **PlayStation Plus subscription** is available, with over **700 games streaming**, and also works on the **PS5** installed in the cinema.

To satisfy all gamers, an **Xbox with Game Pass** has been installed in the mountain area upstairs.

## Workstations

With teleworking becoming more widespread, we felt it was important to provide **three workstations**. The one in the 'Aravis' suite is equipped with a Macintosh with a 23" screen.

The shepherd's table conceals a powerful PC with a 21" Eizo screen. And the desk in the 'Mont-Blanc' suite will accommodate your laptop.

A **printer** and **scanner** complete the installation. None of this would work without a fast network. And just in time, our Starlink connection offers a **speed of over 150 Mb/s**. Ideally, of course, you won't have to reconnect during your stay.



Almost every room is equipped with high-intensity **USB wall chargers**. Use the various cables you'll find to quickly recharge your mobile devices.

When we rearranged the room, we had to use the electricity from the partitions we removed. In the end, the location of the controls isn't very intuitive. So to help you **find the switch you're looking for**, here's a diagram...

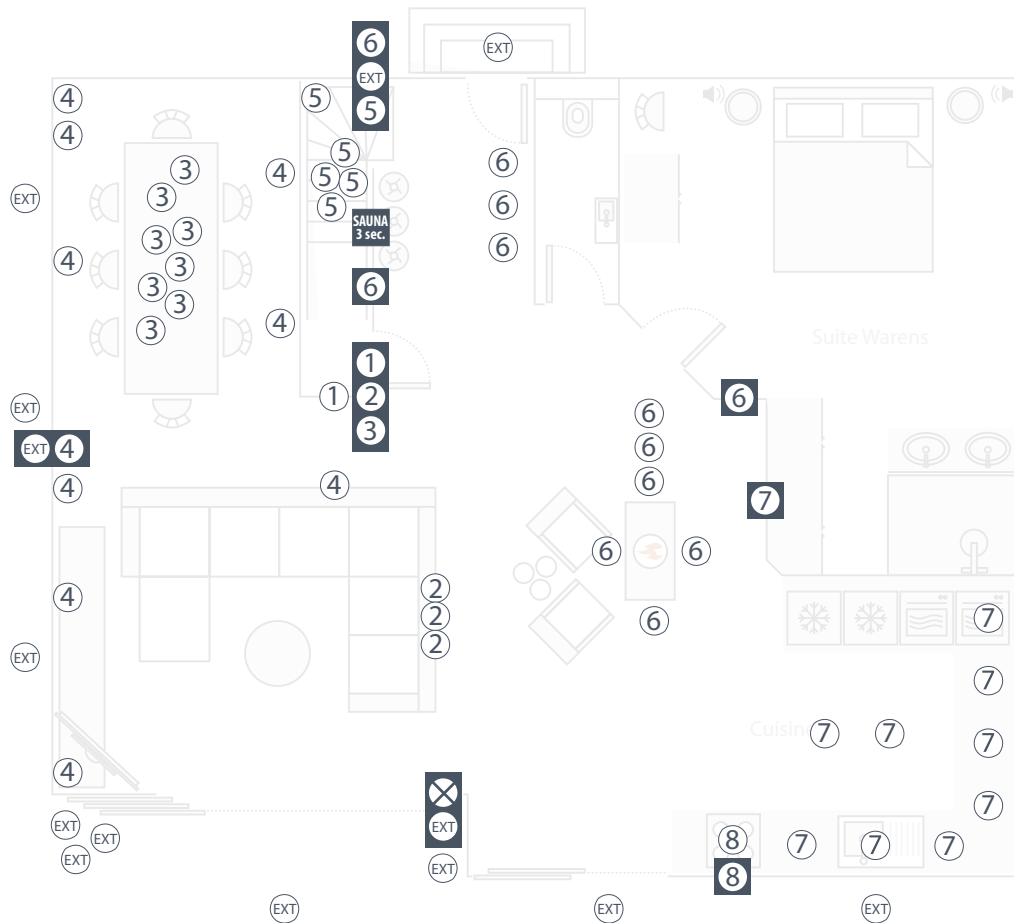

## Video subscriptions

TV channels are available via DTT or Molotov. All screens are connected to an AppleTV, giving you access to **Netflix, Prime, Disney+ and AppleTV+**.

Want to rent a film? Just ask us and we'll be happy to unlock it remotely. **Above all, don't change the subscription identifiers, as you won't be able to restore them at the end of your stay, and you'll be depriving our next guests of this service.**

## The cinema room

To start a cinema session, begin by **manually switching on** the processor and the 3 amplifiers. The switches for the amplifiers are the small black buttons below the large silver ones. The red standby LEDs will light up on power-up. You then need to press the silver buttons for the lights to turn yellow.

Please **turn off the amplifiers at the end of the session** using the black switches, as these little audiophile marvels have the unfortunate tendency to consume more than 800 Watts on standby.

Then simply follow the instructions on the RTI remote control. The programming includes closing the curtains, lowering the screen and controlling the lights.

If you need to use the original remote controls, start by closing the curtains with the Makita remote control, then switch on the projector with the Sony remote control; the screen will lower after 10 seconds. Then use the AppleTV remote to access the subscriptions.

## Sonos speakers

To listen to **music**, download the **Sonos app** onto your smartphone and connect to the chalet's WiFi network. Open the app and select "connect to an existing system". You'll then be able to access the **Deezer, GooglePlay, Amazon Music, Spotify and Apple Music** catalogues to stream to the room or rooms of your choice. Sonos speakers are also compatible with Apple's AirPlay system.

The **Moove** speaker goes everywhere. It's not afraid of the rain or the cold. Think of the peace and quiet of our neighbours outside: they like music just as much as you do, but not too loud or too late. You can recharge it by returning it to its cradle.

## Heating

Nest **thermostats** allow you to control the heating in 7 zones (living room, bedrooms, cinema, massage room). **The controls on the radiators must not be used**. The temperature displayed in the centre of the thermostat corresponds to the set point, and the temperature on the notched wheel to the room temperature. The background turns orange when the radiator heats up. The rooms are programmed to 16°C (60°F) during the day and 21°C (70°F) at night. **We can change the setting remotely**, so don't hesitate to let us know so we can adjust it to suit your needs.

The **LED candles** are lit by remote control. Batteries and two chargers are stored in the drawer of the workbench.

We've taken great care to choose quality bedding. The **duvets** are double-insulated, and the beds are covered with a soft goose-down mattress topper.

## For the perfect hammam session:

Before entering, drink a glass of water or herbal tea. Take a lukewarm shower, wash and dry off.

### **The first phase (warming up) generally lasts 15 to 20 minutes.**

As well as steam, you can also enjoy aromatherapy, with essential oils chosen to awaken, refresh, stimulate or relax. Chromotherapy also has a beneficial effect on the body and mind. Finish off with a cool shower and lie down for a few minutes of relaxation. This is the time to gently rub your body with a horsehair glove.

**The second phase (cooling down).** After the Turkish bath, it's very pleasant to expose yourself to the outside temperature or cool off with a cool shower or sponge bath. Thanks to your body temperature, you'll spend several minutes in a pleasant feeling of freshness and well-being. This phase involves cooling off to escape the intense heat of the hammam, but also to tone the body.

**The third phase consists of another Turkish bath-cold shower cycle.** At the end of the first two phases, relax for at least a quarter of an hour, perhaps with a light, relaxing massage.

Replenish lost fluids by drinking water, fruit juices or herbal teas. It's best not to have an empty or overfull stomach. A light, cool snack is ideal.

To sum up: **Hot shower** 2' | **Hot tea** 6' | **Horsehair Glove** 2'  
**Hammam** 10/15' | **Cool shower** | **Hammam** 10'  
**Cool shower or cool bath** 2' | **Rest** 20' | **Drink.**





## The steam room in the "Aravis" suite

Before activating the function, check that the balneotherapy cabin door is closed. Press the bottom button (2) to start the steam room session. The programmed duration is **90 minutes**. To interrupt the cycle, simply press the same button (2). At the end of the cycle, the LED will flash to indicate the rinsing and steam generator phase.

**Chromotherapy:** press button (1). The pre-programmed duration is 60 minutes. The first press activates a **bluish light**. A second press scrolls through **all the colours in the spectrum**. Choose a fixed colour by pressing a third time. To switch everything off, press a fourth time.

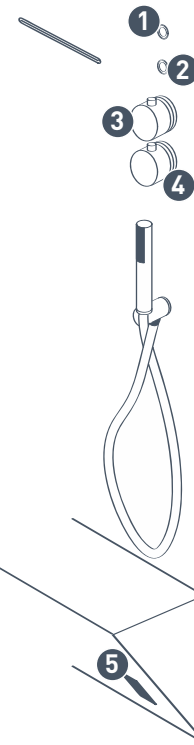

**Showers:** Turn the valve (3) to the left to select the **waterfall**, to the centre for the **shower head** and to the right for the **hand shower**. Then turn towards you to make the water flow.

**Aromatherapy:** Before the session, you can insert a cotton pad soaked in a **few drops of eucalyptus essential oil** into the diffuser (5). The diffuser becomes very hot during the cycle and water may leak out. We advise you to move slightly to the right to **avoid any risk of burns**.

**Music:** select the "GLASS 1989" device to pair the **Bluetooth speaker** with your phone or computer.

**We advise you not to let children use this equipment alone. You are responsible for the use of this equipment.**

## The steam room in the "Mont-Blanc" suite

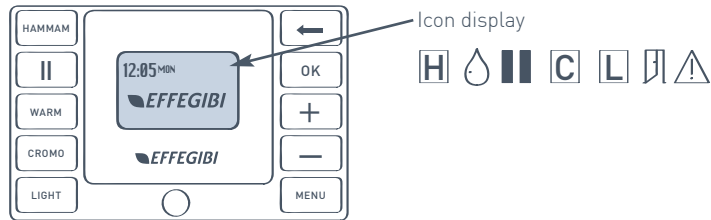

To **start the session**, press the HAMMAM button. The **H** icon is displayed. Press + or - to **set the desired temperature**. The display shows SET TEMP, confirm by pressing OK.

A **white light comes on outside the cabin** in the top left corner of the door. When the temperature is reached, the **light turns blue** and the steam room session can begin.

To **stop the steam generator**, press the HAMMAM button again; after a few seconds, the generator will start the washing procedure, which will last 15 minutes. The **water drop icon** will appear during this phase.

Press key II (pause) while the generator is running (**H** icon on the display) **to interrupt steam production**. If you press key II (pause) again within 30 minutes, steam production will resume. Otherwise, the generator will switch off automatically.

Press the WARM button to activate the production of hot air **to heat the shower cubicle**. Is this really useful?

Press CROMO to activate **chromotherapy**, the **C** icon will appear. Use the + and - buttons to choose the colour. Note that ROSSO (red) - GIALLO (yellow) - VERDE (green) - BLU

(blue) - ACQUAMARINA (aquamarine) are fixed colours. ALBA (dawn) - TRAMONTO (sunset) - MARE (sea) - BOSCO (forest) are dynamic cycles.

Press the LIGHT button to switch the **white light** on or off. **L** will appear on the display.

The MENU button is used to create a **programme**. We advise you not to use it. To cancel daily programming (Set start), simply press the HAMMAM button twice. The **H** icon should not appear on the display.

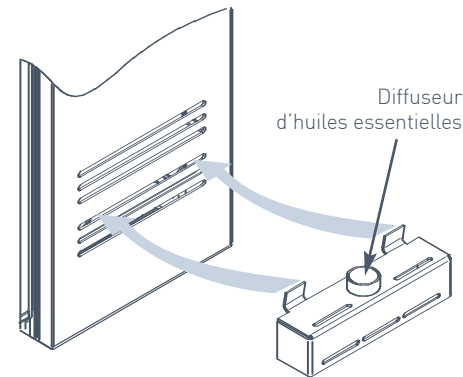

**If the door is not closed properly, the door symbol will appear on the display. Check that the cabin is airtight, otherwise you will hear a beep 40 seconds later. The steam generator will then pause automatically after a further 20 seconds.**

**Aromatherapy:** before starting the session, you can insert a few drops of **eucalyptus essential oil** inside the diffuser. The diffuser becomes very hot during the cycle and water may leak under the baffle.

Check that the baffle is properly inserted in the grille before starting a session. This is designed to protect you from the **risk of burns**.

**If the warning symbol appears on the screen, please contact us as soon as possible and stop using the Turkish bath.**



The interior of the chalet is completely **non-smoking**, but there is an ashtray outside. **Pets** — no matter how adorable — are not allowed.

A **telescope** (x90) and tripod are stored in the trunk of the Mont-Blanc suite.

The **fireplace** must be used with the insert closed, firstly because this is the best way to heat the room, and above all for safety reasons and to avoid poisoning yourself. With the fireplace open, kitchen ventilation would prevent carbon monoxide from escaping up the chimney flue. **Firelighters** are available outside on the balcony or terrace. For your safety, never use alcohol or petrol to start a fire.

Fire and carbon monoxide detectors **are installed on each floor** to warn you of the danger. Press the central button to deactivate the siren. A **water extinguisher** is installed on the staircase leading to the cellar, and a second **CO<sub>2</sub> extinguisher** is strategically placed under the electrical panel.

A **roof window** can be opened using the wall-mounted remote control located on the landing. Note that **it closes automatically** in the event of rain.

The **Forge Adour griddle on the balcony** can be used in summer and winter, and as it is electric, you only need to turn the knobs to start it up. The blue LED goes out when the enamelled plate is at temperature. Don't forget to unfold the shelves on either side, so you can cook at your leisure.

You'll find all the utensils you need in the drawer, as well as delicious recipes in our culinary library. At the end of cooking, when the hob is still hot, pour water over it to loosen the burnt fat, which will then drain into the grease tray. All

you have to do is empty it and clean it in the sink, as this cast aluminium tray does not like dishwashers at all.

To protect the electrical installation from the elements, we've installed two **circuit breakers** on the balcony railings. You'll need to turn the knobs to the vertical position to use the sockets that are flush with the floor. Don't forget to turn them back to the horizontal position after use, as you could risk a power cut if it rains or snows.

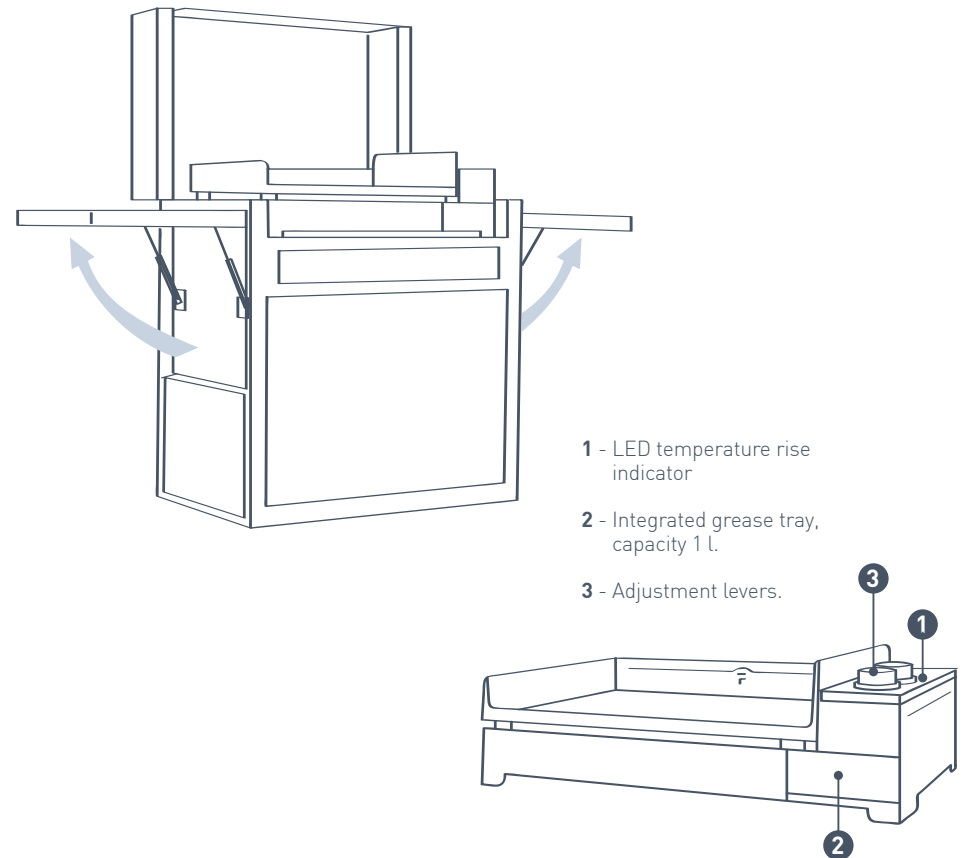

The **floor sockets on the terrace** work on the same principle, activated directly from the electrical panel. Again, don't forget to switch them off after use.

The **Vulx gas griddle** is a wonderful tool for socialising. You can grill tapas while sipping a cocktail and admiring Mont Blanc. All you have to do is open the tap on the gas bottle in the hatch, and the burner controls under the tray. The fire is lit from above, after removing the central part of the tray. Let us know as soon as a bottle is empty so that we can replace it.

Next to the garden furniture, the **Vulx coffee table/brasero** invites you to enjoy a wood fire outside... as long as you take a few precautions. Avoid loading the fire too much, as the wind can turn and blow the flames towards the sofas. Don't panic, you'll find **two dry powder extinguishers** outside; one in the apiary, and a second near the jacuzzi.

We suggest you move them closer to the fireplace when you're using the brazier. A rack and a grill will enable you to make tasty beef ribs over the coals. These accessories are located in the plancha cabinet on the balcony.

You'll find a **parasol** and the **cushions for the garden furniture** in the lockers. Remember to protect them in case of rain. If they get wet, you won't be able to lounge on the sun loungers and sofas.

Under the wisteria arbour, you'll find a discreet **garden shower**. In fine weather, turn the mixer tap to the left for hot water. Please note that the shower cannot be used during the frosty season.

Before your stay, the **spa water** has been scrupulously checked. A professional sand filter and continuous chlorine and pH checks ensure that the water is of the highest quality. Suncream, lotions,

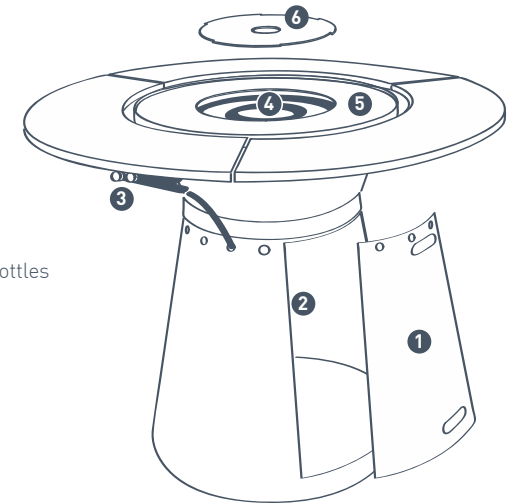

- 1 - Access hatch.
- 2 - Location of Shesha gas bottles
- 3 - Burner controls.
- 4 - Double crown burners.
- 5 - Cooking plate.
- 6 - Removable central plate.

Remove the access hatch and open the gas inlet on the regulator. Remove the removable central plate to gain access to the burners. Open the burner controls and light them with a flame. Replace the centre plate and access hatch.

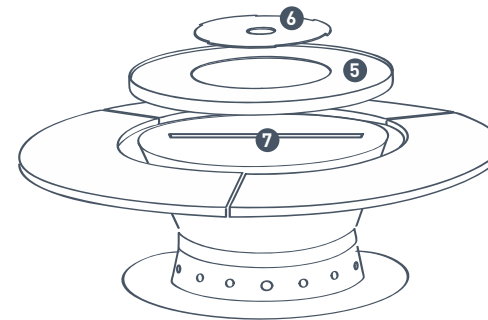

- 5 - Cooking plate.
- 6 - Removable central plate.
- 7 - Wood-burning fireplace.

Remove the removable central plate and the hob. Empty the firebox (if necessary) and light a fire. If you wish to use the Vulx as a plancha, replace the two plates. Do not replace them if you wish to use it as a brazier.

When you leave, put the lid on to smother the fire.

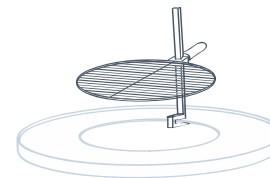

Use the grill and its support to cook over an open fire.

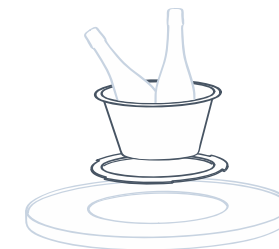

Install the ice bucket to cool your bottles.



- A** - Air inlet valve (Venturi effect), seats 2-3-4.
- B** - Shoulder fountain control, seat 1.
- C** - Reversing valve: Allows massage power to be divided between seat 1 and seats 2-3-4.
- D** - 3-jet cascade control, seat 4.
- E** - Air inlet valve (Venturi effect), seats 5-6-7
- F** - Air supply valve (Venturi effect), seat 1.
- G** - Control board.

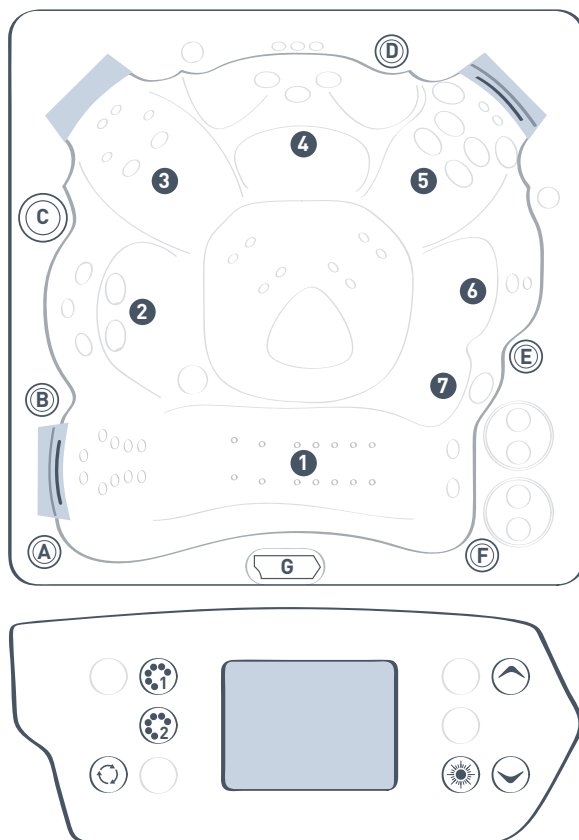

Activate the first massage pump by pressing . Places 5-6-7, the shoulder fountains and the 3 jet waterfall will start to work. Press a second time to increase the power.

To activate the second pump, press to switch on the massage jets in seats 1-2-3-4.

Open the air inlets to create a Venturi effect and give a stronger massage.

Press to activate a chromotherapy cycle, slowly changing colours from one to another. Press briefly twice in succession to illuminate the spa with the colour of your choice.

Press to access the 8 massage programmes.

Use the buttons to make your choice and confirm. Position the diverter in the middle to balance the flow between all the positions. You will need to wait about two minutes, the time needed to drain the spa, before starting your hydrotherapy programme.

perspiration and soap affect the balance of the water. Take a **shower without soap** before entering the pool. Of course, you could not do this, but then you would run the risk of foam appearing and you would no longer be able to enjoy crystal-clear water.

**Don't hesitate to let us know if the quality of the water declines, and we'll take action as quickly as possible.**

The spa is equipped with a **hydrotherapy programme**. Simply select one of the 8 massage programmes from the control panel: *sports recovery, diet activation, heavy legs, insomnia, headaches, backache, wake-up call or stress*. You will then be invited to move to different zones according to the jets. The spa itself manages the lighting, the power of the massages and the duration of the cycles. It is transformed into a real wellness centre thanks to the programmes, each with a targeted therapeutic effect.

You can **adjust the power of each jet individually** at any time by turning them a quarter turn.

At the end of each massage session, switch off the jets and enjoy the warm bath without massage for 3 to 5 minutes to rest the activated areas. Massage cycles last 15 minutes, while chromotherapy is active for one hour. Both will switch off automatically after this time. If you replace the **hard cover** between each use, you'll keep the water at the right temperature, prevent impurities and protect your children from the risk of drowning. Use the cover lifter: raise the two black metal arms, fold the cover in half and slide it to the stop of the cover lifter. This will make it easier to open.

If the water is too hot, there is a **risk of hyperthermia**, so we advise you not to bathe at over 38.5°C (101.5°F).





You can switch on the sauna from inside the chalet or from the cabin by pressing the On/Off button for three seconds. A countdown timer will appear, followed by a beep (or alternatively, from inside the cabin, wait for the yellow light to appear). Allow half an hour for the sauna to reach a temperature of 80°C (176°F). After an hour, it will switch off, so you'll need to restart it manually.

#### Here are a few tips on how to use the sauna properly:

Take off your glasses or contact lenses and remove any jewellery that could be burnt by the heat. You need to have time - the session lasts between **1 h 30 and 2 h**. It's important to complete the 4 steps of the ritual at each session.

Do the session at least 2 hours after eating to avoid any discomfort or nausea.

Bathrobes are available in each room.

#### The sauna ritual is divided into 4 phases

**1. Hot shower** — Before any sauna session, it is essential to take a hot shower, firstly to cleanse your skin, but also to start warming up your body and activate sweating. You need to dry off well before entering the sauna, warm and dry.

**2. The dry steam bath** - The cabin temperature should be between 60°C (140°F) and 100°C (212°F), with an average of around 80°C (176°F), and the humidity level should not exceed 30%. It's best to enter the sauna naked, with only a towel around your waist and a second towel to lie on.

The first time you enter the sauna, lie down. The temperature is lower and you'll feel less oppressive. On subsequent visits, you can sit down if you can bear it.

Relax, take the opportunity to unwind and meditate. When the sweat rolls off your body, it's time to get out. At this point, evaporation through the skin is no longer sufficient and the body starts to cool down. This should be around 10 minutes, never more than 15 minutes.

**3. The cold shower** — Once you're out, take a cold shower, starting with your feet and legs and working up to your shoulders and face. The coolness will trigger a physiological overexcitement, allowing the body to burn off the residue (this will have the same effect as a fever). Dry yourself well.

**4. Rest** — lie down with your legs slightly elevated and cover yourself with a blanket. Rest for 15 minutes, contemplating the mountains, before repeating the 4 phases. Start again with a hot shower.

#### *A little naturopathic advice:*

*If you're not sweating, carry out the ritual as indicated. Your sweat glands will resume their function after several sessions.*

*Over time, the sessions will become shorter and shorter, as your skin will be trained and you'll start to sweat quickly.*

*If you start to feel unwell, go outside when you feel the need and continue the ritual. Your body will gradually get used to it. There is no point, and it would even be dangerous, in forcing yourself to stay longer.*

*After the final rest, brush the skin dry to remove any dead skin and residue and take a hot shower. After your shower, take the opportunity to apply an oil with a few drops of an essential oil of your choice.*

*At the end of the session, remember to drink at least a litre of water to finish eliminating the toxins that have been put back into your bloodstream and to rebalance your body's water requirements.*

*If you can, avoid drinking for an hour before and during your sauna session, so that you can eliminate more toxins and acids. However, the first few times, if you feel the need, drink. Your body will gradually get used to it. Don't force yourself!*

### **The benefits of a sauna session:**

- Stimulates blood circulation. Helps the cardiovascular system to function properly. It also helps to keep blood pressure down.
- Relaxes muscles, providing rapid relief after a sports session.
- Reduces joint stiffness.
- Boosts our immune system. The sauna puts the body into a state of "artificial fever", which stimulates the immune system and leads to increased production of white blood cells and antibodies to fight disease.
- Sweating flushes out toxins accumulated in the body.
- Helps our internal eliminators: kidneys and liver.
- Anti-stress: calms the nerves and eliminates tension.

- Helps you sleep: a session before bed helps you sleep better.
- Skin beauty through deep cleansing: softer, purer, brighter, firmer skin.
- Fights skin problems: acne, psoriasis, eczema, hives.
- Anti-cellulite. Does not make you lose weight, but accompanies a diet.
- Reduces coughing in cases of bronchitis.

### **Here are the cases in which the sauna is not recommended:**

- **The consumption of alcohol**, drugs or antihypertensive medication before the session is totally forbidden.
- **Multiple sclerosis**: heat is not indicated for this condition, which could exacerbate the symptoms.
- **Varicose veins**: as blood circulation is activated, this could be very painful. However, in the case of small varicose veins, you can carry out the session by placing a damp towel over the varicose veins.
- **Infectious diseases**, to avoid contaminating other people.
- **A recent heart operation or heart attack**: as the heart is under great strain, it is preferable to wait until you have stabilised before having a sauna session. However, the sauna is perfectly suitable for re-educating the heart and strengthening it in the event of a heart problem. Ask your doctor for advice before any session.
- **Fever**: as the heat causes an artificial fever, your fever will rise considerably and could become dangerous.





11 km of ski slopes

During the season, the **free shuttle bus** stops twice a day in front of the chalet to take you to the slopes. From the village centre, the shuttle runs more frequently, departing every half hour.

### E.S.F. (French Ski School)

#### Cordon

71, Chemin de la Charbonnière  
 74920 Cordon — +33 4 50 58 13 63  
<http://www.cordon.fr/hiver/ecole-de-ski-francais.htm>

### To go skiing in Cordon:

Follow Route des Miaz towards Route de Cordon//D113  
**1 min (600 m)**

Turn right at Route de Cordon/D113  
**1 min (450 m)**

Follow Route de Cordon/D113 and Route de la Jorasse towards Route de Frebougues d'en Haut  
**8 min (4,5 km)**





Cordon, Combloux, Megève, La Giettaz, Saint-Gervais,  
Les Contamines, Hauteluce, Saint-Nicolas de Véroce.

450 km of ski slopes



Cordon, Combloux, Megève (Jaillet),  
La Giettaz

100 km of ski slopes

## To go skiing in the «Portes du Mont-Blanc» & «Évasion Mont-Blanc»

Follow Route des Miaz towards Route de Cordon  
Cordon/D113

**1 min (600 m)**

Take Route de Barlioz and Route de Barthoud towards  
Route de Bourgeois in Combloux

**6 min (3,0 km)**

Follow Route de Bourgeois and Route du Vernay towards  
Route des Brons

**8 min (3,7 km)**

### E.S.F. (French Ski School)

#### Combloux

Maison du Tourisme

49, Chemin des Passerands - 74920 Combloux

+33 4 50 58 60 87

[www.esf-combloux.com](http://www.esf-combloux.com)

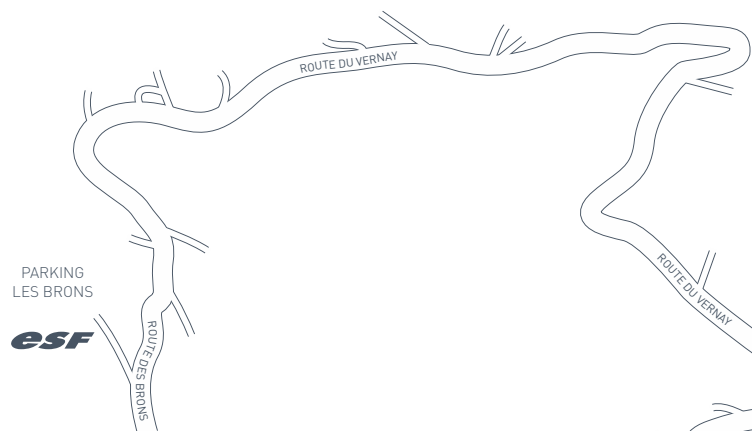

-42-

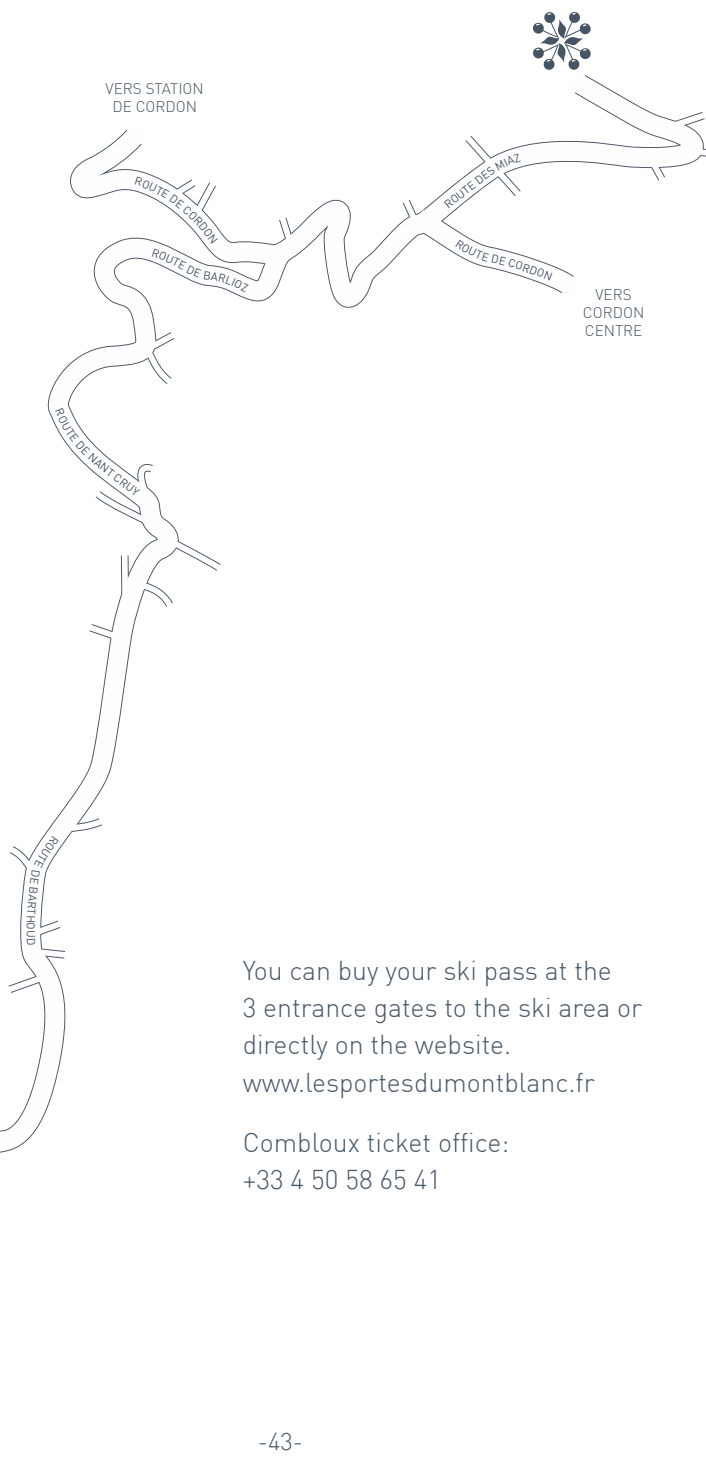

You can buy your ski pass at the  
3 entrance gates to the ski area or  
directly on the website.  
[www.lesportesdumontblanc.fr](http://www.lesportesdumontblanc.fr)

Combloux ticket office:  
+33 4 50 58 65 41

-43-

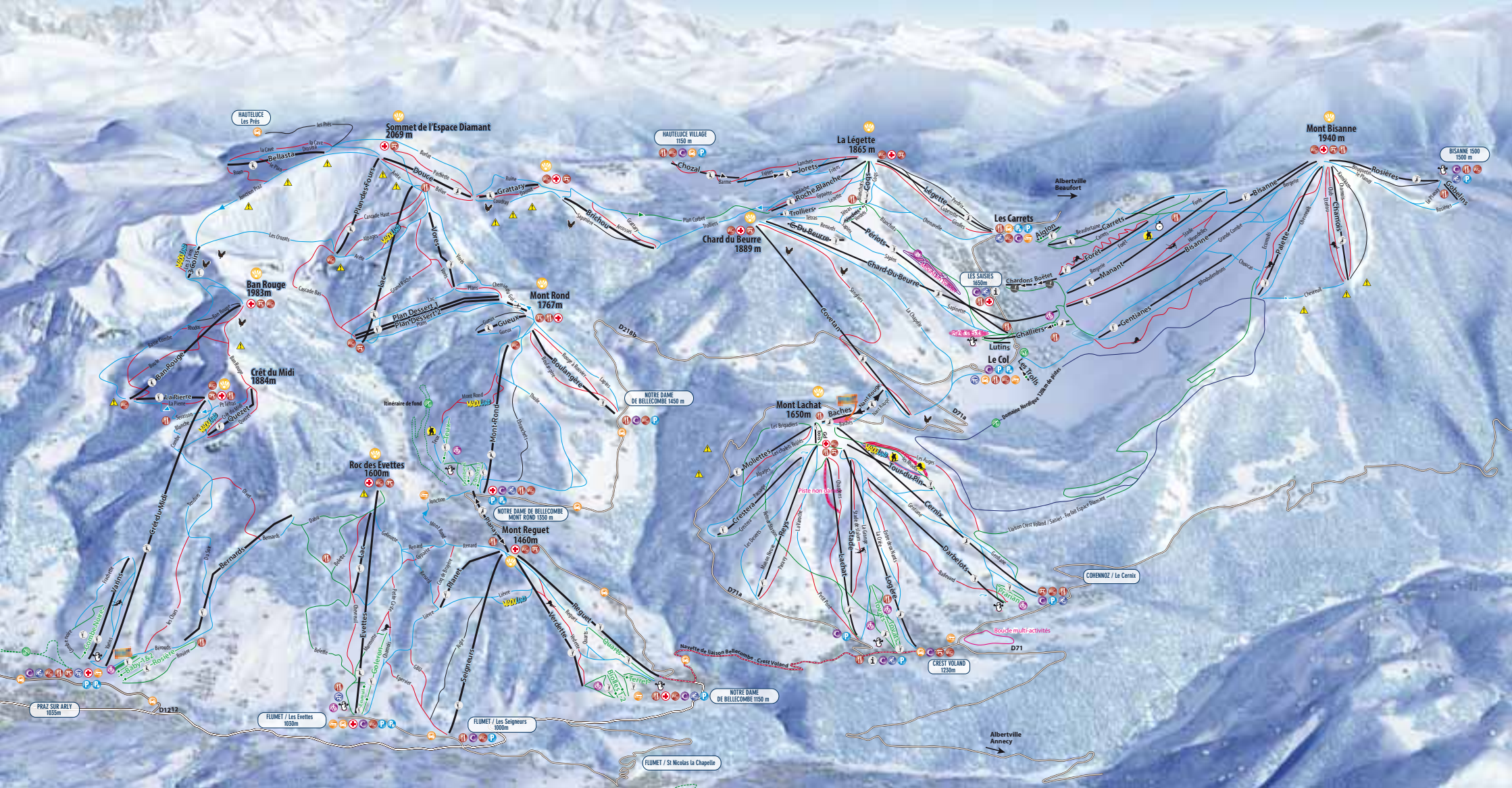

Praz-sur-Arly, Flumet, Notre-Dame de Bellecombe,  
Crest-Voland/Cohenoz, les Saisies/Hauteluice.

192 km of ski slopes

## To go skiing in the « Espace Diamant »

Take Route des Miaz, Route de Barlioz, Route de Barthoud, Route de la Combe and Route du Pelloux towards Route de Sallanches/D1212 in Combloux.

**9 min (5,0 km)**

Follow D1212 towards Route des Belles in Praz-sur-Arly.

**13 min (9,9 km)**

Continue on Route des Belles Head toward Allée de la Mairie.

**2 min (700 m)**

### E.S.F. (French Ski School) Praz-sur-Arly

6, route de Megève

74120 Praz sur Arly

+ 33 4 50 21 90 34

[www.esf-prazsurarly.com](http://www.esf-prazsurarly.com)

VERS  
ALBERTVILLE

PRAZ  
SUR-ARLY  
ACCÈS AUX PISTES  
(4,2 KM)

TRAVERSER  
MEGÈVE  
(4,7 KM)

TRAVERSER  
COMBLOUX  
(1 KM)

D1212

-46-

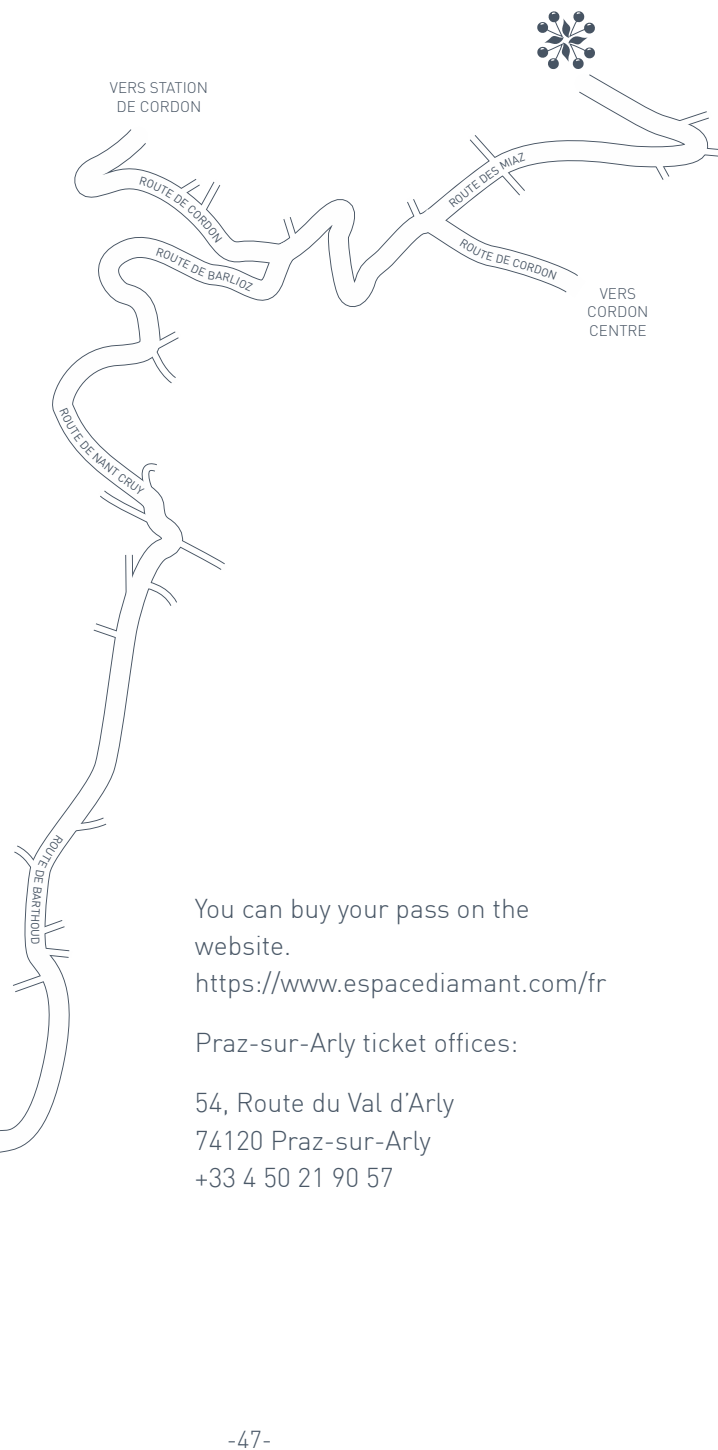

You can buy your pass on the website.

<https://www.espacediamant.com/fr>

Praz-sur-Arly ticket offices:

54, Route du Val d'Arly

74120 Praz-sur-Arly

+33 4 50 21 90 57

-47-





## Babysitters

### Les Enfants d'Abord

*Babysitting agency based in Lyon since 1996 - Branch in Megève.*

+ 33 4 72 73 11 46 — <https://www.lesenfantsdabord.fr>

Anne Bottolier: +33 6 65 28 14 40 - Élise Bottolier: +33 6 47 42 43 13  
Cassandra Calie: +33 6 49 41 45 68 - Charlotte Darchy: +33 6 61 58 61 60  
Sabine Deberies: +33 6 19 17 08 95 - Enora Desbouis: +33 7 82 82 24 12  
Manon Gibault: +33 7 86 10 63 84 - Axelle Nio: +33 6 81 76 41 95



### Restaurant “La Charrette” (5 km)

*Traditional restaurant, our favourite.*

73, Ancienne Route de Combloux — 74700 Sallanches +33 4 50 58 00 59  
[www.facebook.com/lacharrette74](http://www.facebook.com/lacharrette74)

### Restaurant “Chez Mireille”, Le Darbelin (5 km, directly on the slopes)

*Considered one of the best restaurants in Cordon.*

1780, Route de Frebourg — 74700 Cordon +33 4 50 58 06 04  
<http://www.ledarbelin.fr>

### Restaurant “La Dolce Vita” (5,3 km)

*This restaurant offers genuine Italian cuisine of the highest quality.*

8, Quai Saint-Jacques — 74700 Sallanches +33 4 50 93 95 86  
<https://la-dolce-vita-restaurant-sallanches.eatbu.com>

### Restaurant “Source” (9,5 km)

*A bistro as we like them, simple and tasty modern cuisine.*

43, Avenue du Mont d'Arbois — 74170 Saint-Gervais-les-Bains +33 4 57 44 41 35  
<https://www.source-restaurant-saint-gervais.com>

### Restaurant “La table d'Armante”, (17,7 km)

*Fabien Laprée invites you to discover a new take on Alpine flavours.*

4088, route de Saint-Nicolas — 74170 Saint-Gervais-les-Bains +33 4 50 78 66 00

<https://www.armancette.com>

### “Corentin Barbier” home chef

*Corentin is bursting with talent. An absolute must during your stay at the chalet.*

*For groups of 6 or more - remember to book your dates in advance.*

+ 33 7 70 37 90 73 — [contact@barbiercorentin.fr](mailto:contact@barbiercorentin.fr)

### “Mountain Mixologist” home barman

*Myles puts on a show with his roving bar and prepares divine signature cocktails.*

+33 6 51 82 80 68 — <https://www.themountainmixologist.com>



### Bar “Chez Kevin” (1,1 km)

*Bar with atmosphere and character, occasional musical evenings.*

*And above all improbable hairdressing evenings.*

Place de l'Église — 74700 Cordon +33 6 15 31 36 86

### Bar “Chez Vez” (5,3 km)

*The must-visit bar! A menu of beers from all over the world and tapas.*

Quai Saint Jacques — 74700 Sallanches



### Supermarket “Sherpa” (1 km)

Centre Village — 74700 Cordon +33 4 50 58 13 35

### “Le Temps des R'zules” (1,2 km)

*Shop selling carefully selected local products.*

2950, Route de Cordon — 74700 Cordon +33 6 88 72 25 07

**“Demange” Bakery (1,2 km)**

*Exceptional baker, awarded by the Gault et Millau guide.*

2900, Route de Cordon — 74700 Cordon +33 6 72 53 36 43

**Pâtisserie “Zanin” (5,5 km)**

*Master Chocolatier-Pâtissier, member of Relais Desserts.*

540, Rue du Général Jacques de Montfort — 74700 Sallanches +33 4 50 34 59 24

<https://www.zaninchocolatier.fr>

**“Satoriz” (6 km)**

*Grocery shop offering fresh organic produce.*

1894, Avenue de Genève — 74700 Sallanches

**Grocery store/supermarket “Grand Frais” (9,1 km)**

*Fruit and vegetables, groceries, butchers, cheesemongers and fishmongers.*

*Open on Sunday mornings.*

Route de Sallanches — 74700 Domancy +33 4 50 96 49 85



**“l’Abérieux” Farm (2,2 km)**

*Open every day from 5.30pm to watch the cows being milked.*

*IGP Tomme de Savoie, Bleu, Raclette, Abérieux, Yoghurts, Milk jam...*

490, Chemin du Pont de la Flée — 74700 Cordon +33 6 76 12 41 67

<http://www.fermedelaberieux.sitew.fr>

**Ferme du “Renard” (9 km)**

*Beef, milk-fed veal, goats, eggs, vegetables, fruit. Every afternoon from 5:pm to 9:pm -*

*Combloux market on Wednesday mornings.*

312, Route de Vouvray — 74120 Demi-Quartier +33 6 78 02 32 89

**Boucherie/Charcuterie ‘Sans os’ (5,3 km)**

*Lots of tasty marinated meats for plancha.*

88, Rue Justin — 74700 Sallanches +33 4 50 58 01 95

**Boucherie-Charcuterie ‘Bello’ (12 km)**

*Matured meat, Wagyu, Galician beef, Pata Negra ham...*

*Exceptional products for wealthy epicureans.*

914, Route nationale — 74120, Megève + 33 4 50 55 91 90

<https://www.boucherie-bello.fr>

**Sl’Huîtrerie Bricou (16 km)**

*Craving oysters, shellfish and seafood? Just one good address...*

4, Place du Crétet — 74300 Cluses +33 4 50 98 53 41

<http://www.huitrerie-bea.fr>

**Cave Francioli**

*A wide selection of old cognacs and rums, with expert advice.*

37, Rue du Faucigny — 74700 Sallanches +33 4 50 58 02 78

<https://www.vins-sallanches.com>

**Cave Collections**

*Fine selection of great wines from all regions, old vintages, rare estates, renowned and up-and-coming producers, old spirits, great spirits, great Italian wines.*

150, Route de la Croix de Pierre — 74920 Combloux +33 4 50 34 92 58

**Les Essentiels d’Ici**

*Angèle & Rémy offer quality regional products.*

*Private tastings of local wines available at the Chalet by prior arrangement.*

Le Fayet — 124, Avenue de Chamonix — 74170 Saint-Gervais-les-Bains +33 6 83 81 66 96

<https://www.lesessentielsdici.fr>

**Saturday — Sallanches market (5 km).**

*For the 'Jourdan' cheese and sausage shop and 'Sibelle' Bresse poultry.*

**Wednesday — Combloux market (7 km).**

*For the 'Renard' farm and 'Marta Vini.'*

**Sunday — Megève market (12 km)**



**Massages at home**

Mélanie can come to the chalet to give you a massage.

+33 6 76 73 85 26

Catherine comes to the chalet for Tuina massages.

+33 6 33 31 64 29

**Foot reflexology and sonotherapy at home**

Agnès comes to the chalet to give you a massage.

+33 6 89 69 00 35



**'Pugnat Sport' (0,7 km)**

*Hire of skis, snowboards, snowshoes, sledges...*

3475, route de Cordon — 74700 Cordon +33 4 50 47 85 84

<http://www.pugnatsports.com>

**Intersport (5,8 km)**

*Hire of skis, snowboards, snowshoes, sledges... Specify that you are staying at the chalet to benefit from discounts.*

9, Chemin de la Promenade — 74920 Combloux +33 4 50 93 33 65

<http://www.intersport-combloux.com>



**Golf du mont d'Arbois (13 km)**

*Located overlooking Megève, at an average altitude of 1320 m.*

3001, Route Edmond de Rothschild — 74120 Megève +33 6 12 11 97 97

**Chamois d'Or Tennis court (0,5 km)**

*Upon reservation, the hotel opens its tennis court.*

4080, Route de Cordon — 74700 Cordon +33 4 50 58 05 16



**Mountain biking and off-piste skiing / Heliskiing instructor**

*Alexandre Bastien, Off-piste specialist, backcountry skiing, ski touring and heli-skiing adventures. Also mountain bike.*

+33 6 12 11 97 97 — [al.bastien@wanadoo.fr](mailto:al.bastien@wanadoo.fr)

**Sallanches Guides and Accompaniers Office (5 km)**

*Off-piste skiing, ski touring, hiking, mountaineering, paragliding.*

32, Quai de l'Hôtel de Ville — 74700 Sallanches +33 6 28 27 58 65

<http://www.guides-sallanches.com>

**Snowmobile / Paragliding / Helicopter 'Les Volatiles' (33,7 km)**

*One of the most beautiful snowmobile trails in France.*

Sport 2000 - 196, Avenue des JO — 73620 Les Saisies +33 4 79 38 95 54

<http://www.les-volatiles.com>

**Alpes Mongolfière (15,5 km)**

*Hot air balloon flights in the heart of the Mont Blanc region.*

101, Route du Val d'Arly — 74120 Praz-sur-Arly +33 4 50 55 50 60

<https://alpes-montgolfiere.fr>

**Session Raft (11,9 km)**

*Specialists in white water and mountain sports.*

1871, Chemin des peupliers — 74190 Passy +33 4 50 93 63 63

<http://www.sessionraft.fr>



### **Biotop lake (5,8 km)**

*Book the day before at the Combloux Tourist Office.*

Chemin du Perret — 74920 Combloux +33 4 50 91 21 62

### **Îlettes lakes (9 km)**

*A fishing lake, a swimming lake and a windsurfing lake.*

Ancienne Route Impériale — 74700 Sallanches

### **Tree climbing 'Passy Plain' wood' (20,5 km)**

*10 metres above ground, in the fir trees.*

Plaine Joux — 300, Chemin des parchets — 74190 Passy +33 6 99 25 76 39  
<https://www.facebook.com/passyplainwood>

### **Karting du Mont-Blanc (11 km)**

Route des Lacs / Chemin du Mont-Blanc plage — 74190 Passy  
+33 6 80 14 68 19

<https://www.kartingdumontblanc.com>



### **Bowling / Laser Game / Escape Game "Bowling du Mont-Blanc" (5,8 km)**

*10 bowling lanes, plus an Escape Game (3 to 8 people)  
and a 3,000 m<sup>2</sup> Laser Game.*

531, 533 Rue du Capitaine Bulle — 74700 Sallanches +33 4 50 18 00 00  
<http://www.bowlingmontblanc.com>



### **Tourist Office (1 km)**

*A wealth of information and electric mountain bike hire.*

Centre Village — 74700 Cordon +33 4 50 58 01 57  
<http://www.cordon.fr>

### **Sallanches - Cordon link / Bus SAT**

+33 4 50 78 05 33 — <http://www.sat-montblanc.com.com>

### **Montenbus**

*This service allows you to travel on demand.*

3650, Route de Cordon — 74700 Cordon +33 4 50 58 04 17 ou 0 800 2013 74  
<http://www.montenbus.fr>

### **Taxi n° 7 — Pascal Savreux**

32, Avenue de Genève — 74700 Sallanches +33 6 09 45 84 11

### **Alpes VTC Transfert**

*9-seater vans for all distances. Stations, airports, resorts.*  
+33 6 34 51 55 05; +33 +33 6 20 85 07 01



### **'Le Mont-Blanc' tobacco shop**

Place de l'église — 74700 Cordon +33 4 50 18 48 67



### **Sallanches Hospital (5,5 km)**

380, Rue de l'Hôpital — 74703 Sallanches +33 4 50 47 30 30  
<http://www.chi-mont-blanc.fr>



### **o contact the doctor on duty in the evening or at weekends:**

Evenings, 7 days a week, from 7:pm to 11:pm,  
go to Sallanches Hospital, where a general practitioner is on call to provide  
non-emergency care.

From 11:pm to 8:am the next day, call 15 for advice.

On Sundays and public holidays, from 8:am to 7:pm,

dial +33 4 50 58 12 12.

Contact the GP on call.



We wish you a wonderful stay  
at the chalet “les Cerises.”

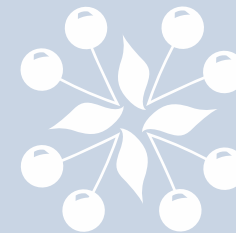

If you have any questions  
advice or information, please do not hesitate  
to contact us:

**+33 6 20 44 77 44**  
Laurent

**+33 6 89 69 00 35**  
Agnès (fluent english spoken)

**[www.chaletlescerises.fr](http://www.chaletlescerises.fr)**  
(Commission-free online booking).

**@chaletlescerises**  
Keep in touch on Instagram, Pinterest and Facebook.